

I/A Series Temperature Products
Model PRMTA Configurable Sensors

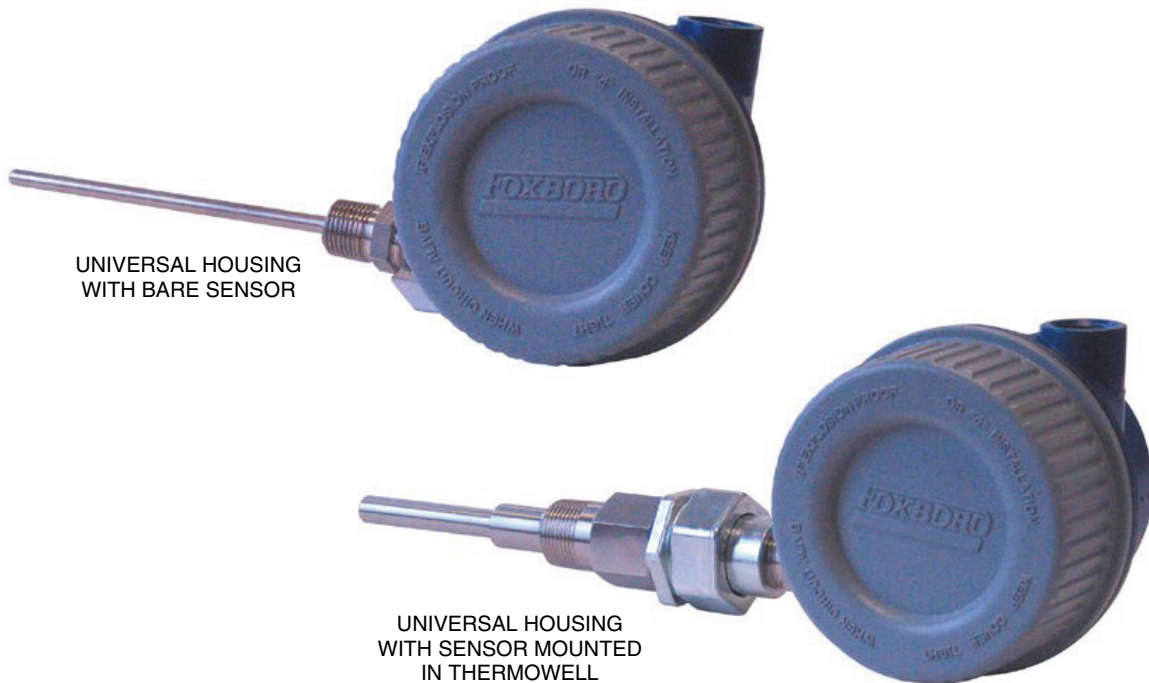

The Foxboro[®] brand PRMTA Series Configurable Sensors are temperature sensors available for use with I/A Series temperature transmitters. The sensors are available as thermocouples or resistance temperature detectors (RTDs) with options that make them well suited for use in a wide variety of applications.

OVERVIEW

PRMTA Configurable Sensors provide many different temperature sensor options for use with I/A Series temperature transmitters. You can order a sensor at the same time you order your temperature transmitter, and the sensor is shipped assembled to the transmitter. Alternately, you can order sensors separately as replacement parts for transmitters in the field. These highly configurable sensors are available with two sensor types: thermocouples or resistance temperature detectors.

Thermocouples

A thermocouple uses two different types of metal conductors to generate a voltage that is proportional to a detected temperature difference.

PRMTA thermocouple wires are surrounded by aluminum oxide insulation and a durable metal sheath to provide an isolated measuring junction. The sheath is annealed to remove stresses and increase flexibility. Moisture is removed (and sealed out) from the assembly to provide a high insulation resistance.

Thermocouples are specified because of their strength, and protection against corrosion and contaminating atmospheres.

For angle use, a bare thermocouple can be bent on a radius as small as 50 mm (2 in).

Small size and compact design result in fast response to temperature changes. Spring-loaded thermocouples used in thermowells provide a temperature response approximately twice as fast as that of a comparable 0.75 mm² or 20 AWG size wire-type thermocouple assembly in a thermowell or in a protection tube.

Resistance Temperature Detectors (RTDs)

RTDs are sensors whose electrical resistance changes with a change in temperature, and they are an ideal selection in applications having a wide temperature range. They measure temperatures from -200 to +650°C (-320 to +1200°F) and are calibrated to either ASTM-A (DIN A) or ASTM-B (DIN B) standard curves. A 3-wire RTD sensor with Callendar-van Dusen coefficients is also available.

LONG LIFE, LOW MAINTENANCE

The use of protective sheathing and thermowells increases the life of the sensor while ensuring low heat loss and suitable thermal response. When thermowells are used, the spring-loaded thermocouple or RTD can be easily removed without process shutdown. Longer sensor life results in lower maintenance costs and reduced spare parts inventory.

A VARIETY OF CONFIGURATIONS

The PRMTA configurable sensors are available in bare sheath or thermowell type assemblies. The bare sensor offers a welded construction for protection against process intrusion. In both configurations, the sensor is protected with a full length moisture resistant sheath of either 316 stainless steel (316 ss) or Inconel 600, depending upon the temperature or process material being measured. An excellent selection of specially engineered thermowells is available to further protect the temperature sensor from physical damage or from corrosive or damaging process media. Thermocouple or RTD insertion lengths are available from 2 to 36 inches (51 to 914 mm) in 1/2 inch (12.7 mm) increments.

SPRING LOADED CONSTRUCTION WITH THERMOWELLS

When thermowells are used, a spring loading device is used to provide positive tip contact between the element and thermowell bottom. This ensures a reliable temperature measurement. Thermowells that can be used with PRMTA configurable sensors are available in the following configurations: Threaded (TT), Flanged (TF), Sanitary (TS), Weld-in (TW), and W-Series thermowells. Refer to "Available Thermowells" on page 5.

ORDERING INSTRUCTIONS

The PRMTA configurable sensors are used with I/A Series Temperature Transmitters. You can order a sensor at the same time you order your transmitter, and the sensor is shipped assembled to the transmitter. Alternately, you can order sensors separately as replacement parts for transmitters in the field.

For example, the RTT80 temperature transmitter model code has several selections that allow you to specify how the transmitter will be used:

- ▶ The RTT80 Housing and Sensor Mounting selection specifies whether the transmitter will be used with a remote sensor, a bare sensor, or a sensor with thermowell mounting capabilities.

A remote sensor must be ordered separately.

- ▶ The RTT80 Input Measurement Type selection configures the transmitter to use a specific measurement type. When you order an RTT80 with sensor or sensor and thermowell mounting capabilities, the RTT80 Input Measurement Type options are limited to the types of sensors that can be supplied by the factory. When you order a PRMTA sensor that will be mounted on an RTT80, the PRMTA Input Measurement Type must match the RTT80 Input Measurement Type.

- ▶ The RTT80 Thermowell Assembled to Housing selection allows you to specify whether a thermowell will be used with the transmitter, and

if so, whether the thermowell will be user-supplied or will be a Foxboro T- or W-Series thermowell.

Ordering instruction examples are shown further in this document on page 13.

PERFORMANCE SPECIFICATIONS

Thermocouple Accuracy⁽¹⁾

Type	Temperature Range		Tolerance (a) (Percentages Expressed are of Reading)
	°C	°F	
Type E	-200 to +900	-328 to +1600	±1.0°C or ±0.4%
Type J	0 to 750	32 to 1400	±1.2°C or ±0.4%
Type K	-200 to +1260	-328 to +2300	±1.2°C or ±0.4%
Type N	-270 to 1300	-454 to +2372	±1.1°C or ±0.4%
Type T	-200 to +350	-328 to +700	±0.5°C or ±0.4%

- a. Whichever is greater. The “percent of reading” limit of error applies to the °C temperature only. To determine the error in °F, multiply the °C error by 1.8.

RTD Accuracy

ASTM-A (DIN A) Calibration Sensors

±0.13 + 0.0017(T)°C, where T = °C temperature, absolute value. (Better than IEC-A calibration accuracy.)

ASTM-B (DIN B) Calibration Sensors

±0.25 + 0.0042(T)°C, where T = °C temperature, absolute value. (Better than DIN and IEC-B calibration accuracy.)

RTD Repeatability

±0.14°C (±0.25°F) or 5%, whichever is greater.

RTD Response Time

5 seconds maximum for a 63% recovery in water stirred at 1 m/s (3 ft/s).

1. Conforms to ANSI MC 96.1.

PHYSICAL SPECIFICATIONS

Dimensions

See Dimensions-Nominal section.

Configurations

Two configurations are offered: a bare sensor and a sensor for thermowell mounting. The bare element-type assembly has a hex-head nipple with 1/2 NPT external thread welded on sensor for process mounting and mounting to connection head.

Figure 1. Sensor Configurations

SENSOR TYPE OPTIONS*

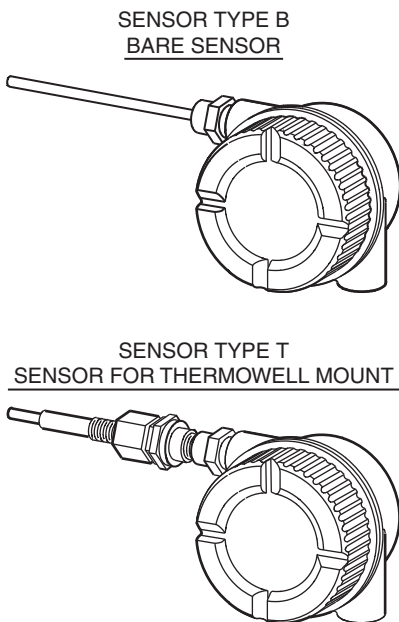

* The sensor type options are shown here with an RTT80 temperature transmitter enclosed in a universal housing (not included).

Sensor Types

THERMOCOUPLES

Single element sensors where thermocouple wires are electrically insulated from the sheath, providing an isolated measuring junction.

RESISTANCE TEMPERATURE DETECTORS

Single resistance temperature sensor, strain free, fully annealed. Stranded 0.50 mm² or 22 AWG wire with pte insulation.

Internal Insulation

Glass fiber over sensitive length; high-purity aluminum oxide powder over remaining length.

Sheath Sealant

Epoxy compound applied at open end of sheath to prevent entry of moisture.

Sheath Outside Diameter (O.D.)

0.250 in (6.35 mm). Note that a thermowell inside diameter (I.D.) of 0.260 in (6.60 mm) is required.

Insertion Length, A, U, or U+T

Refer to Model Code.

Construction

All welded and moisture sealed, with options for 316ss or Inconel sheath materials, depending on sensor types and temperature requirements.

Insulation Resistance between Lead Wire and Sheath

Greater than 100 MΩ at 50 V dc and 25°C (77°F).

Thermowells





Foxboro thermowells isolate the process and separate the temperature-measuring sensitive portion of the sensor from potentially corrosive or damaging process media. These thermowells permit ready removal of the sensor without process shutdown. A selection of plain or lagged, threaded or flanged, solid, welded, or tapered thermowells is available in a variety of sizes and materials. The thermowells are machined from industry standard materials, and a polished finish assures maximum corrosion resistance. They are manufactured in accordance with applicable ASME, ASTM, and ANSI standards.

Available Thermowells

Thermowells that can be used with PRMTA configurable sensors are available in the basic configurations listed below: Threaded (TT), Flanged (TF), Sanitary (TS), Weld-in (TW), and W-Series thermowells.

Note:

For additional information and thermowell specifications, refer to PSS 3-3C1 A for W-Series thermowells, and to PSS 3-3D1 A for T-Series thermowells.

Thermowell Type	Material	Process Connection/ Flange Size
Threaded (TT) 	<ul style="list-style-type: none"> ▶ Carbon steel ▶ 304 ss ▶ 316 ss ▶ Monel ▶ Nickel alloy (a) ▶ Alloy 20 	<ul style="list-style-type: none"> ▶ ½ inch NPT ▶ ¾ inch NPT ▶ 1 inch NPT
Flanged (TF) 	<ul style="list-style-type: none"> ▶ Carbon steel ▶ 304 ss ▶ 316 ss ▶ Monel ▶ Nickel alloy(a) ▶ Alloy 20 	<ul style="list-style-type: none"> ▶ 1 inch flange ▶ 1½ inch flange ▶ 2 inch flange ▶ 3 inch flange
Sanitary (TS) 	<ul style="list-style-type: none"> ▶ Carbon steel ▶ 304 ss ▶ 316 ss ▶ Monel ▶ Nickel alloy(a) ▶ Alloy 20 	<ul style="list-style-type: none"> ▶ ¾ inch tri-clamp ▶ 1 inch tri-clamp ▶ 1½ inch tri-clamp ▶ 2 inch tri-clamp ▶ 3 inch tri-clamp
Weld-In (TW) 	<ul style="list-style-type: none"> ▶ Carbon steel ▶ 304 ss ▶ 316 ss 	<ul style="list-style-type: none"> ▶ 1.05 inch diameter, socket weld ¾ inch pipe ▶ 1.315 inch diameter, socket weld 1 inch pipe ▶ 1.5 inch diameter, socket weld-in

a. Equivalent to Hastelloy® C. Hastelloy is a registered trademark of Haynes International, Inc.

Thermowell Internal Diameter

0.260 in (6.6 mm)

Thermowell Shank Types

- Straight
- Stepped
- Tapered

Thermowell Insertion Length (U-Length)

2 in (50.8 mm) through 36 in (914.4 mm) in 0.5 in increments

Thermowell Lagging Length (T-Length)

0 (no lagging)
or
2.0 in (50.8 mm) through 4.0 in (101.6 mm) in 0.5 in increments

SENSOR FUNCTIONAL SPECIFICATIONS

Temperature Limits

The maximum temperature limit is determined by the lowest upper range limit (URL) of the element or sheath.

THERMOCOUPLE ELEMENT

Refer to "Thermocouple Accuracy" on page 3.

RTD ELEMENT

-200 and +650°C (-320 and +1200°F)

316 ss SHEATH

-200 and +480°C (-320 and +900°F)

INCONEL SHEATH

-200 and +650°C (-320 and +1200°F)

Thermocouple Sensor Calibration

ANSI MC 96.1, Types E, J, K, N, or T as specified.

RTD Sensor Calibration

Per ASTM E1137-87. Resistance at 0°C (32°F) is as follows (also conform to DIN and IEC calibrations):

for ASTM-B, $100.00 \pm 0.10 \Omega$

for ASTM-A, $100.00 \pm 0.05 \Omega$

Refer to TI 005-028. Alpha is $0.00385 \Omega/\Omega/^\circ\text{C}$.

Vibration Effect

Less than 0.05°C (0.09°F) for sensor in a 0.250 inch O.D. sheath of 3 inches (76 mm) of unsupported length under 250 m/s² (25 "g") vibration, in any axis, from 20 to 2000 Hz in a 15 minute interval.

External Pressure Effect

Less than 0.01°C (0.005°F) for sensor in a 0.250 inch O.D. during exposure to 21 MPa (3000 psi).

RTD Self Heating

Bare sensor immersed in an ice bath stirred at 1 m/sec (3 ft/sec) is 64 mW/°C (35 mW/°F).

OPTIONS AND ACCESSORIES**Option -C1: Calibration Certificate**

A 3-point calibration with certificate is provided. For standard or special calibration curve, specify Optional Selection -C1.

Option -C5: Cleaned and Prepared for Oxygen Service

This provides cleaning and preparation of materials for oxygen and chlorine service. For certification of the cleaning, specify Cert G in the Auxiliary Specification section.

Accessory: RTD to Instrument Cable

Three wires, stranded copper, 1.0 mm² or 18 AWG. Polyethylene insulation is 8.4 mm (0.33 in). Temperature limit is 90°C (195°F). Specify Part Number R0101LY and desired length.

MODEL CODE

Description	Model
Model PRMTA Configurable Sensor	PRMTA
Element	
Single	-1
Duplex (a)	-2
Sensor Type	
Bare sensor	B
Sensor for Thermowell mount	T
Input Measurement Type	
Thermocouple, Type E	E
Thermocouple, Type J	J
Thermocouple, Type K	K
Thermocouple, Type N	N
Thermocouple, Type T	T
3-wire RTD, 100 ohm platinum IEC 751 (ASTM-B standard accuracy)	Q
4-wire RTD, 100 ohm platinum IEC 751 (ASTM-B standard accuracy)	4
3-wire RTD, 100 ohm platinum IEC 751 (ASTM-A high accuracy)	A
4-wire RTD, 100 ohm platinum IEC 751 (ASTM-A high accuracy)	6
3-wire RTD, Callendar-van Dusen	W
Not Used	
None	N
Sheath (0.25 inch OD) (b)	
Inconel	F
316 Stainless Steel	S
Insertion Length (A-length or U-length) (c)	
2.0 inches (50.8 mm)	0020
2.5 inches (63.5 mm)	0025
3.0 inches (76.2 mm)	0030
3.5 inches (88.9 mm)	0035
4.0 inches (101.6 mm)	0040
4.5 inches (114.3 mm)	0045
5.0 inches (127.0 mm)	0050
5.5 inches (139.7 mm)	0055
6.0 inches (152.4 mm)	0060
6.5 inches (165.1 mm)	0065
7.0 inches (177.8 mm)	0070
7.5 inches (190.5 mm)	0075
...	XXXX
36.0 inches (914.4 mm)	0360
Lagging Length (T-length) (d) (e)	
0 inches (0 mm) ^(d)	000
2.0 inches (50.8 mm)	020
2.5 inches (63.5 mm)	025
3.0 inches (76.2 mm)	030
3.5 inches (88.9 mm)	035
4.0 inches (101.6 mm)	040
Optional Features	
Three-Point Calibration with Certificate	-C1
Cleaned and Prepared for Oxygen Service (f)	-C5

- a. Note that not all duplex sensor types may be able to connect to one temperature transmitter. Consult transmitter product literature for allowable connections.
- b. Sheath material (Inconel and stainless steel) represents an electrically isolated sensor when pertaining to thermocouples.
- c. Insertion length represents the U-length for sensors with thermowells (Sensor Type T) and the A-length for bare sensors (Sensor Type B). Specify the desired insertion length in increments of 0.5 inches up to a maximum of 36.0 inches (914.4 mm). Substitute numerical values for the four character positions, where the last character position is a "0" or "5" and represents the digit after the decimal point. For example, "0165" represents a 16.5 inch insertion length.
- d. For sensors with thermowells (Sensor Type T), the lagging length defined for the PRMTA must match the lagging length defined for the thermowell. For bare sensors (Sensor Type B), select zero lagging length (Selection 000).
- e. Specify the desired lagging length in increments of 0.5 inches from 2.0 inches (50.8 mm) up to a maximum of 4.0 inches (101.6 mm). Substitute numerical values for the three character positions, where the last character position is a "0" or "5" and represents the digit after the decimal point. For example, "035" indicates a 3.5 inch lagging length.
- f. Optional Selection -C5, Cleaned and Prepared for Oxygen Service, provides cleaning and preparation of materials for oxygen and chlorine service, and only applies to replacement sensors. For certification of cleaning, order Cert G in the Auxiliary Specifications section.

Figure 2. PRMTA Configurable Sensors: Bare Sensor and Sensor For Thermowell Mount

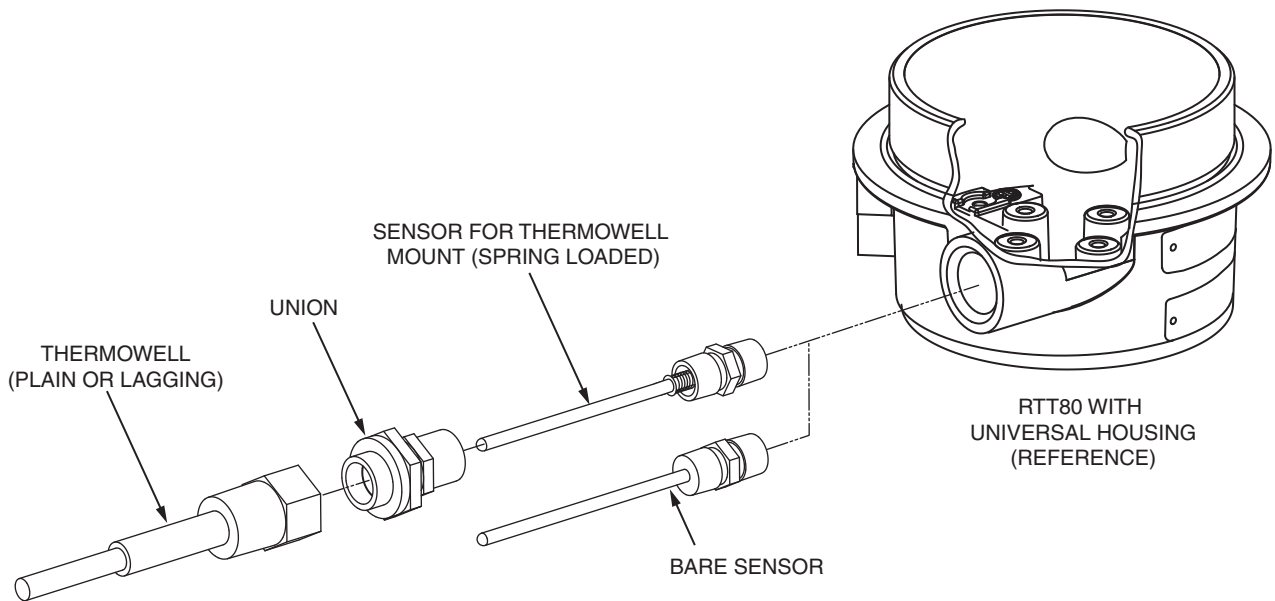

DIMENSIONS – NOMINAL

$\frac{\text{mm}}{\text{in}}$

A = Bare Sensor Length (without thermowell)
 U = Thermowell Insertion Length
 T = Thermowell Lagging Length

NOTES

1. When using Sensor Type T without lagging, the sensor length must equal the insertion length of the thermowell (U).
2. When using Sensor Type T with lagging, the sensor length must equal the insertion length plus the lagging length of the thermowell (U + T).

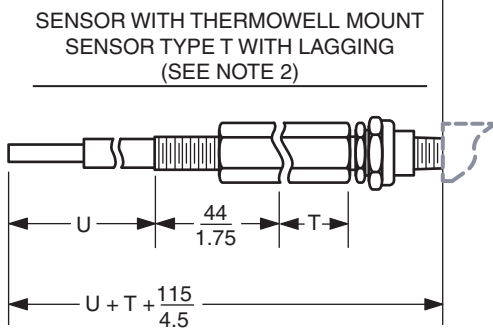
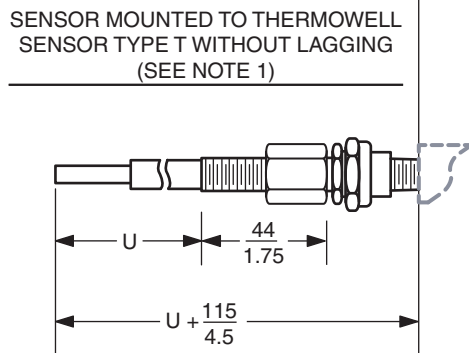
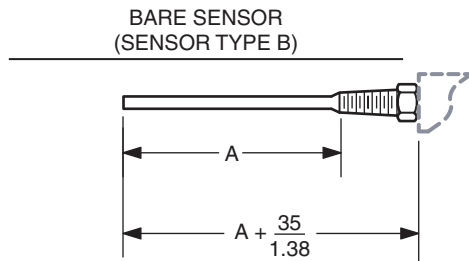

ORDERING INSTRUCTIONS: EXAMPLE 1

- ▶ Bare sensor configuration
- ▶ 3-wire standard accuracy RTD sensor type
- ▶ 2.5 inch insertion length (A-length)
- ▶ No lagging.

PRMTA Model Number from this PSS:

e.g., PRMTA-1BQNS0025000-C1

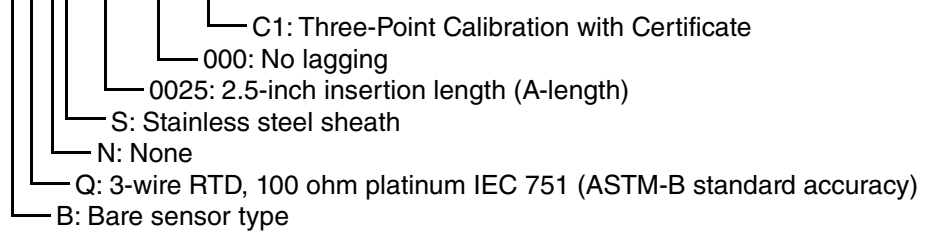

ORDERING INSTRUCTIONS: EXAMPLE 2

- ▶ With sensor and thermowell mounting
- ▶ Type N thermocouple sensor type
- ▶ 7.5 inch insertion length (U-length)
- ▶ No lagging.

PRMTA Model Number from this PSS:

e.g., PRMTA-1TNNS0075000

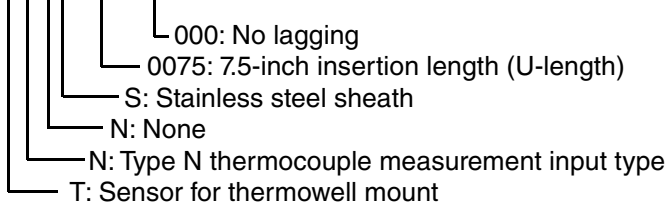

T-Series Thermowell Model Number from PSS 3-3D1 A:

e.g., TT-2CB307500

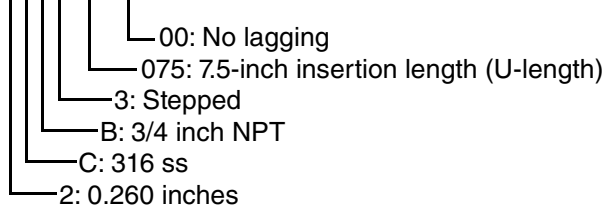

ORDERING INSTRUCTIONS: EXAMPLE 3

- ▶ With sensor and thermowell mounting
- ▶ Type N thermocouple sensor type
- ▶ 7.5 inch insertion length (U-length)
- ▶ 10.0 inch lagging length (T-length).

PRMTA Model Number from this PSS:
e.g., PRMTA-1TENS0075100

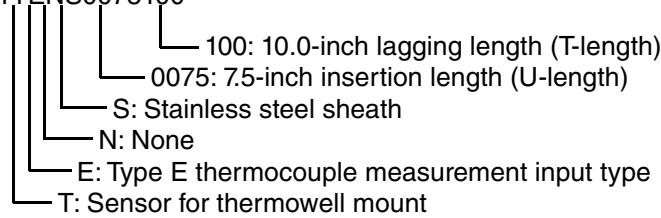

ORDERING INSTRUCTIONS

1. Model Number
2. Thermowell, as required
(refer to PSS 3-3D1 A for Standard T-Series thermowells,
and to PSS 3-3C1 A for W-Series thermowells).
3. Accessories
4. User Tag Data

OTHER FOXBORO PRODUCTS

The Foxboro product lines offer a broad range of measurement and instrument products, including solutions for pressure, flow, analytical, temperature, positioning, controlling, and recording. For a list of these offerings, visit our web site at:

www.fielddevices.foxboro.com